



REFRIGERATION

SERVING THE FOOD INDUSTRY SINCE 1951

## 27-INCH UNDER COUNTER FREEZER

Item: 50053 Model: FR-CN-0686-HC

*The perfect solution to add cold storage space for frozen products and ingredients conveniently within reach*



### FEATURES

- Stainless steel interior and exterior
- Refrigeration system keeps food at safe temperatures between -8°F and 0°F / -22°C to -18°C
- Self-closing doors with 90 degree stay-open feature
- Adjustable heavy-duty PVC coated shelves
- Digital control system makes it easy to adjust temperature set point and defrost frequency
- This unit uses HYDRO-CARBON R290 refrigerant, which is environmentally friendly and more efficient



### WARRANTY

2 YEARS PARTS & LABOR  
5 YEARS ONLY ON COMPRESSOR



NEMA  
5 - 15  
125 VAC / 15 AMP



Authorized Dealer

# REFRIGERATION

27-INCH UNDER COUNTER FREEZER **FR-CN-0686-HC**



## TECHNICAL DRAWINGS AND DIMENSIONS

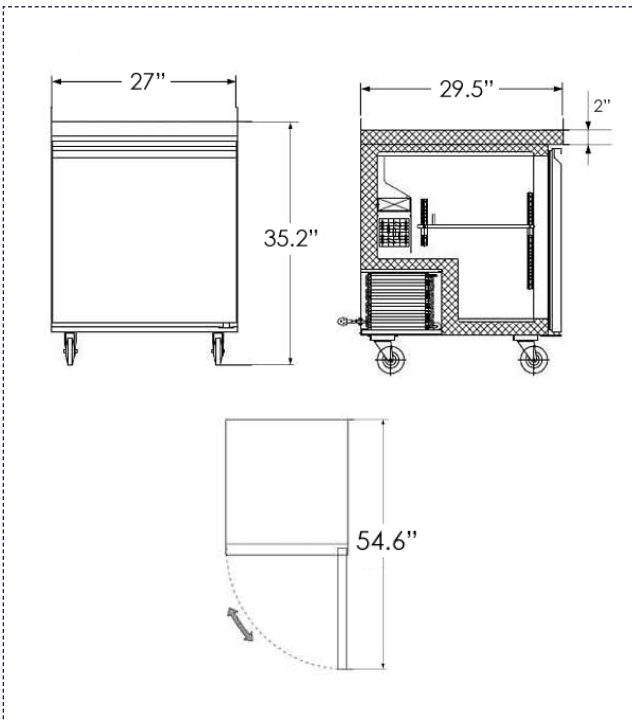

## PRODUCT SPECIFICATIONS

ITEM NUMBER	<b>50053</b>
MODEL	FR-CN-0686-HC
DESCRIPTION	27-inch Under Counter Freezer
TEMPERATURE RANGE	-8°F - 0°F / -22°C - -18°C
POWER	1/5 HP
REFRIGERANT	R290
ISOLATION MATERIAL	Cyclopentane
COOLING SYSTEM	Ventilated
DEFROSTING	Automatic
TYPE OF CONTROLLER	Digital
SELF-CLOSING DOOR	Yes
AMPS	2.1
NUMBER OF DOORS	1
NUMBER OF SHELVES	1
SHELF MATERIAL	Coated steel
SHELF LOADING (KG/PC)	20 kg. / 44 lbs.
ELECTRICAL	115V / 60Hz / 1Ph
INTERIOR DIMENSIONS (WDH)	22.2" x 22.8" x 23.5" 565 x 580 x 597 mm
OVERALL DIMENSIONS (WDH)	27" x 29.5" x 35.2" 685 x 750 x 895 mm
PACKAGING DIMENSIONS	30 3/8" x 32 5/8" x 38 5/8" 770 x 830 x 980 mm
NET VOLUME (CU. FT.)	6.3 cu. ft. / 177 L
WEIGHT	81 kg. / 178 lbs.
PACKAGING WEIGHT	106 kg. / 233 lbs.

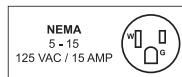

## OMCAN INC.

Telephone: 1-800-465-0234

Fax: (905) 607-0234

Email: sales@omcan.com

Website: www.omcan.com



Follow us to keep up to date with the latest news and offers



2016.E.O.E